

VIEW FROM NON-TRAFFIC SIDE

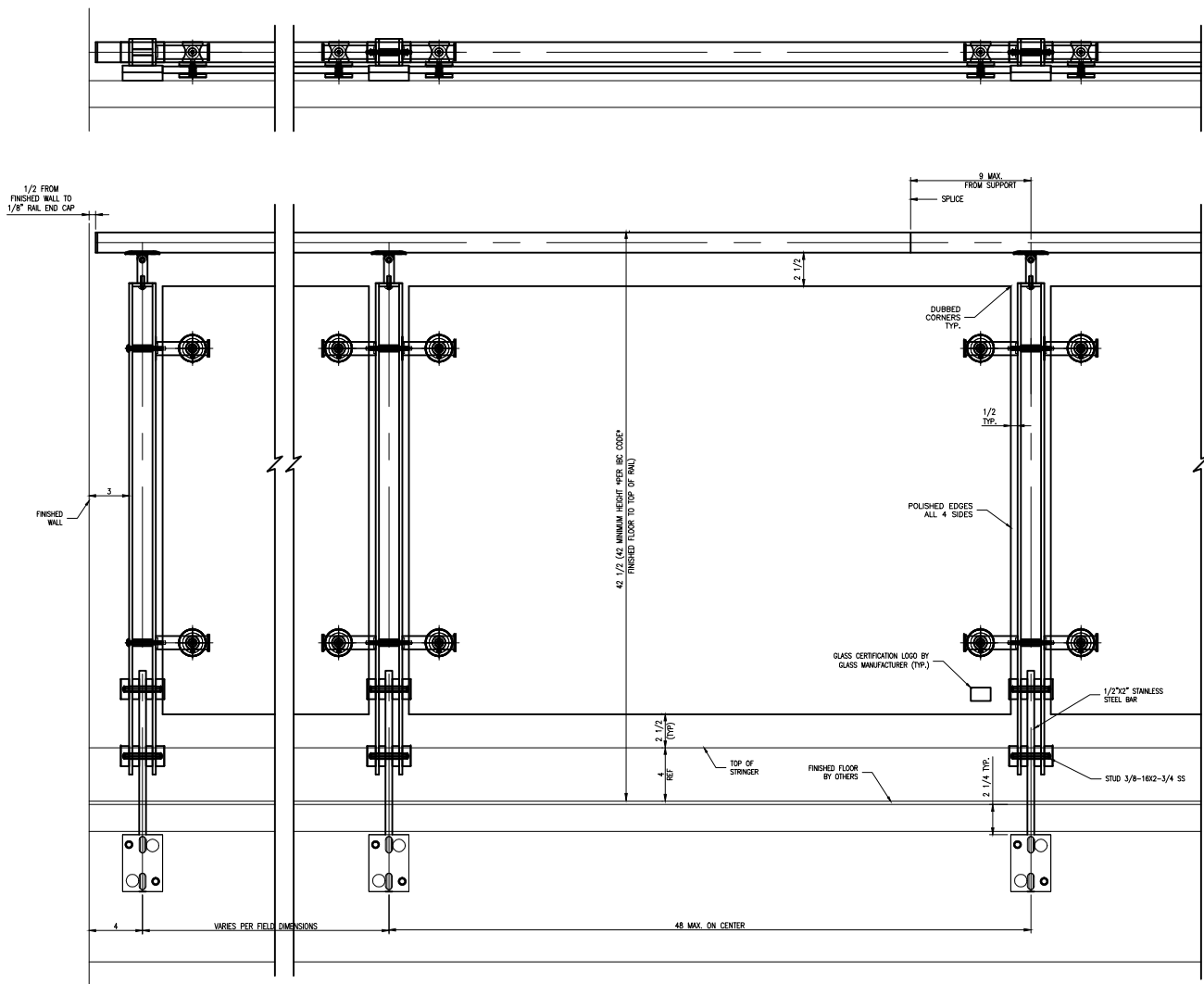
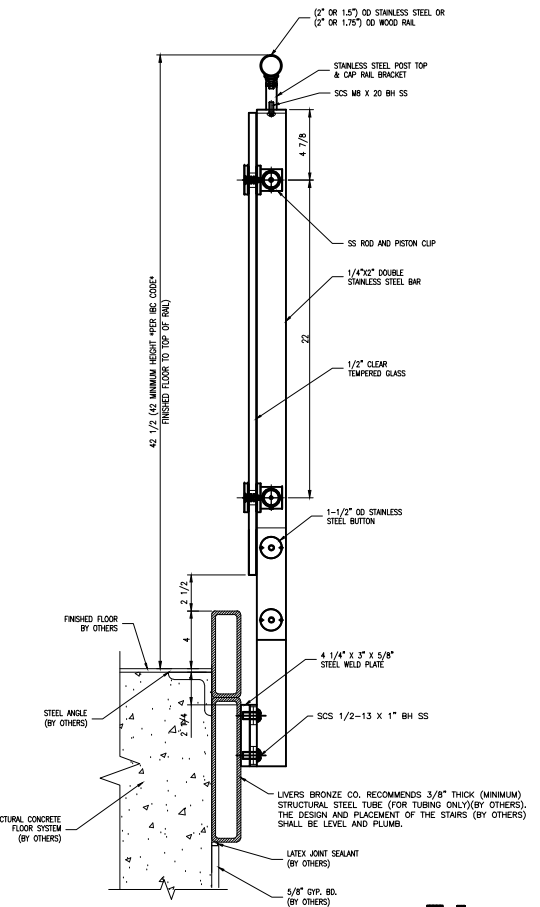

1/2\"/>

9 MAX.  
FROM SUPPORT  
SPLICE

42 1/2\"/>

DUBBED CORNERS  
TYP.

1/2\"/>

POLISHED EDGES  
ALL 4 SIDES

GLASS CERTIFICATION LOGO BY  
GLASS MANUFACTURER (TYP.)

1/2\"/>

STUD 3/8-16x2-3/4 SS

2 1/2\"/>

REF

TOP OF  
STRINGER

FINISHED FLOOR  
BY OTHERS

2 1/4\"/>

VARIES PER FIELD DIMENSIONS

48 MAX. ON CENTER

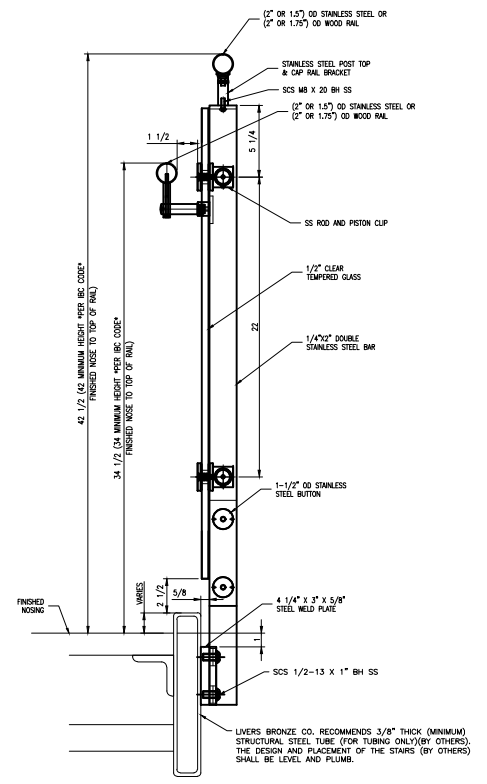
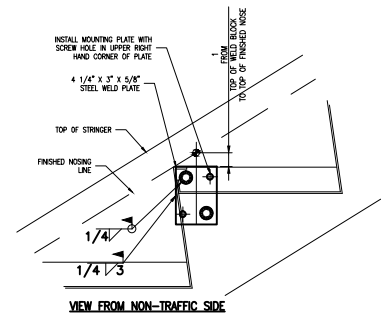
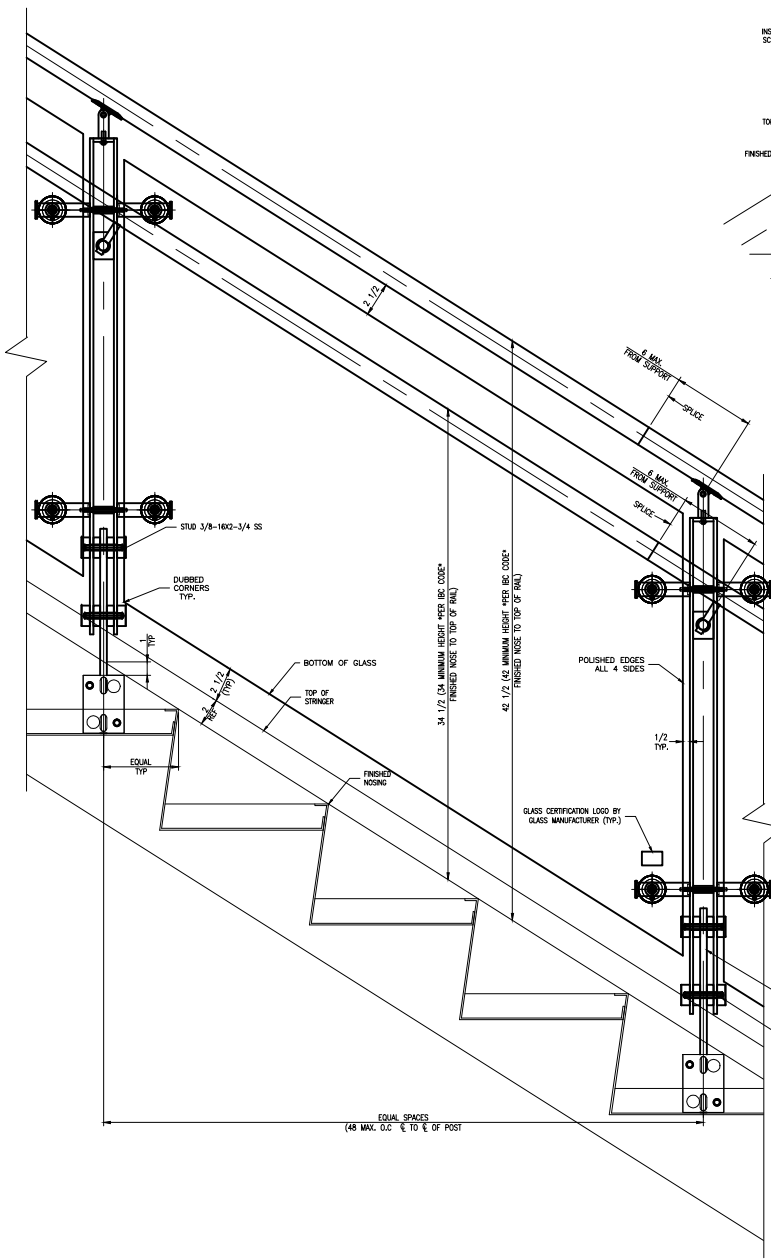

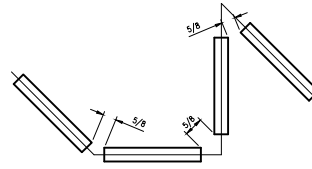

TYPICAL GLASS CORNERS DETAIL  
SCALE: 6" = 1'-0"

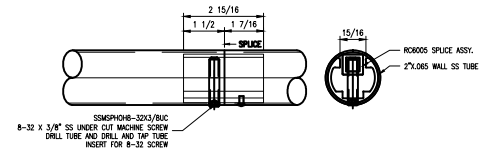

FACTORY CUT SPLICE  
SCALE: 6" = 1'-0"

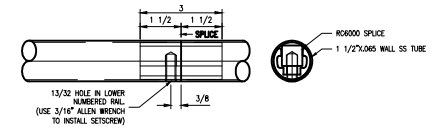

FACTORY CUT SPLICE  
SCALE: 6" = 1'-0"

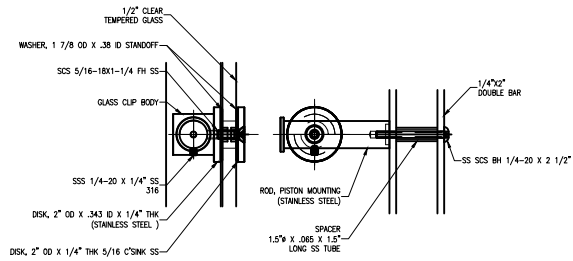

ROD-PISTON ASSEMBLY -END POST  
SCALE: 6" = 1'-0"

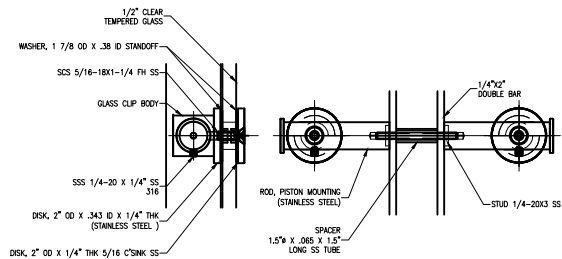

ROD-PISTON ASSEMBLY-INT POST  
SCALE: 6" = 1'-0"

**LIVERS  
BRONZE**

4621 East 75th Terrace Kansas City, MO 64132  
Phone (816) 300-2828 / Fax (816) 300-0864  
www.liversbronze.com  
livers@liversbronze.com